



Ex mark: Ex de op is IIC T5 Gb
Ex op is tb IIIC T95°C Db, IP66

Characteristics

- It is made using a special aluminum housing, anti-corrosion performance than 304 stainless steel, suitable for long-term highly corrosive environment of offshore platforms, chlor-alkali, hydrogen sulfide, etc.
- The anti corrosion, abrasion proof, power coated cover which is dust proof, water proof, make the lamp an excellent option for all kinds of high environment.
- All 304 stainless steel bracket screw (customizable 316), can effectively guarantee the long-term strength and strong corrosion problems of lamps.
- Terminals are provided at both ends, can be directly wired in parallel, eliminating the junction box and installation costs.
- A variety of installation as optional: ceiling, oil derrick, the side walls, curved rods, boom, etc.

Application

- It can be widely used in petrochemical plants, oil platforms, oil pump housing, transit stations and other flammable and explosive places as fixed lighting.
- Gas explosive environment: Group IIA, IIB, IIC.
- Zone1, Zone2; Zone21, Zone22

Light Distribution Curve

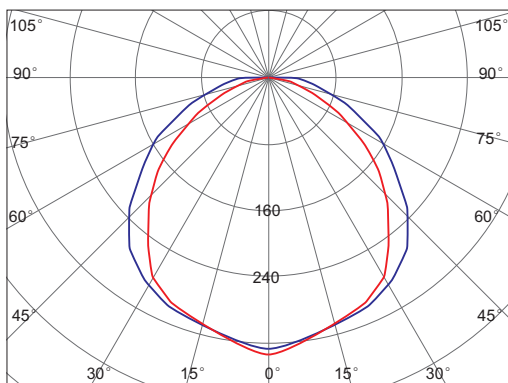

Space Height Ratio: 1.5
— 0°
— 90°

Main Specification

Item	Technical Parameters	
Rated wattage (W)	2×20W	2×10W
Emergency wattage (W)	20W	10W
Input voltage (V)	90~264VAC	
Rated frequency	50Hz / 60Hz	
Light source	LED	
Light efficiency (lm/W)	90	
CRI	80	
Life time (h)	50,000	
CCT	5000K	
Emergency duration (min)	90	180
Time of charging (h)	6	
Rated capacity	2.6Ah/14.8V	
Leading-in cable diameter	φ 10mm~ φ 14mm	
Cable entry	G3/4", M25×1.5, NPT3/4"	
Dimension (mm)	(2×20W) 1390×180×110	
	(2×10W) 780×180×110	
	(Emergency box) 230×220×105	
Net weight (kg)	10.7	6.6
	(Emergency box) 2.8	

BC5401J LED Explosion Proof Emergency Light

TORMIN

Drawing of Dimension (Dimensions in mm)

Ceiling mounting

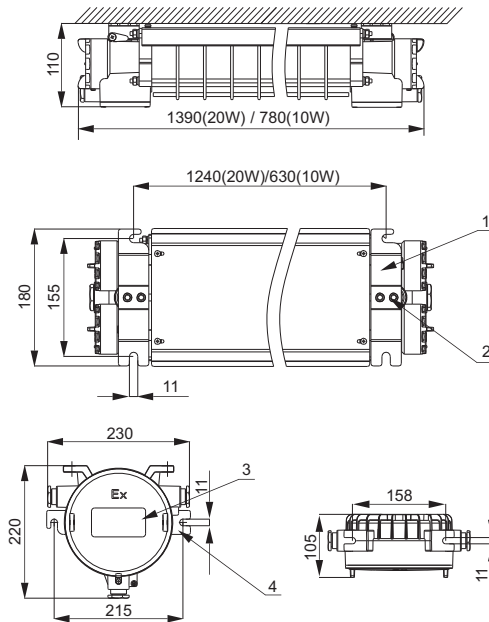

BXP01 Explosion-Proof Emergency Box

Lamps ordering information

Order No.	Installation	Emergency wattage	Emergency duration
BC5401J-L2 × 10	ceiling	10W	180min
BC5401J-L2 × 20		20W	90min

Fitting ordering information (Standard)

Order No.	No.	Specification	Quantity
P01	1	Ceiling Bracket	2
	2	M8 Inner six angle bolt	4

Emergency box ordering information (Standard)

Order No.	No.	Specification	Quantity
BXP01	3	Explosion-Proof Emergency Box	1
	4	Bracket	1

Derrick installation

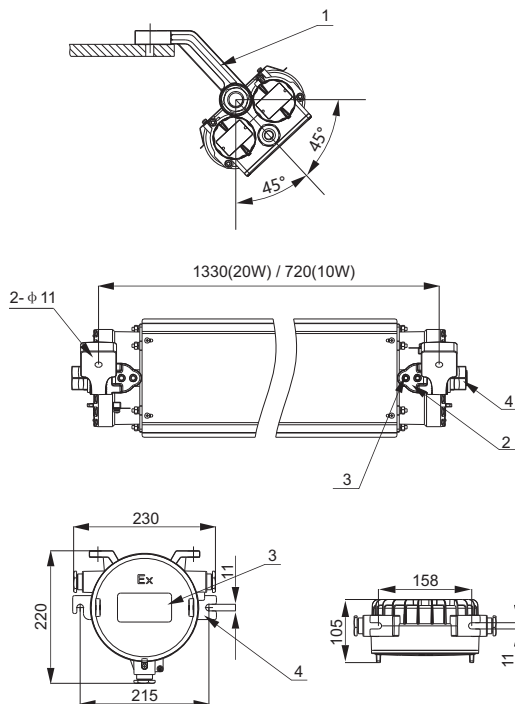

BXP01 Explosion-Proof Emergency Box

Lamps ordering information

Order No.	Installation	Emergency wattage	Emergency duration
BC5401J-L2 × 10	Derrick type	10W	180min
BC5401J-L2 × 20		20W	90min

Fitting ordering information (Optional)

Order No.	No.	Specification	Quantity
P02	1	Derrick bracket	2
	2	Base	2
	3	M8 Inner six angle bolt	4
	4	M24 screw	2

Emergency box ordering information (Standard)

Order No.	No.	Specification	Quantity
BXP01	3	Explosion-Proof Emergency Box	1
	4	Bracket	1

Side wall mounting

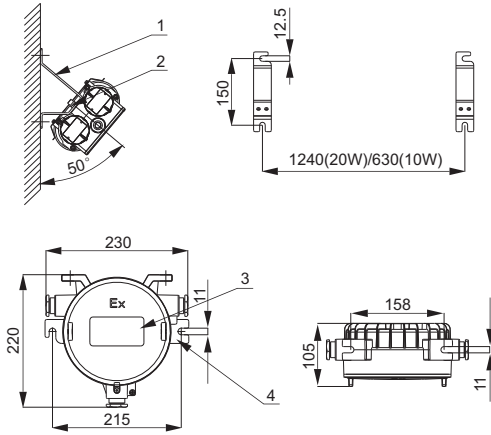

BXP01 Explosion-Proof Emergency Box

Rod mounting

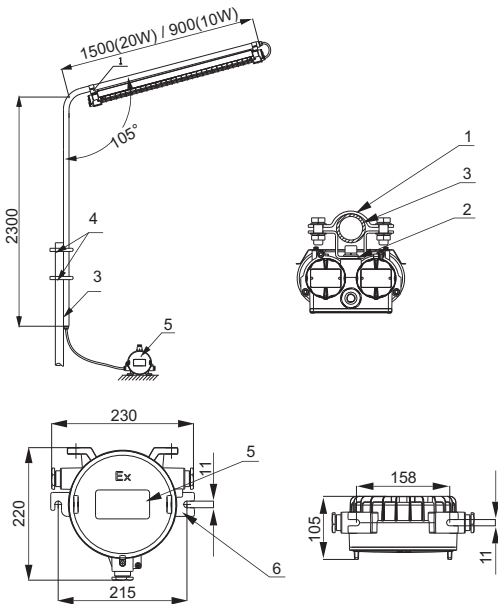

BXP01 Explosion-Proof Emergency Box

Pole mounting

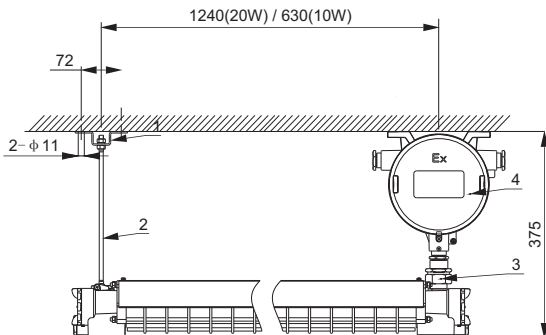

Lamps ordering information

Order No.	Installation	Emergency wattage	Emergency duration
BC5401J-L2×10	Sidewall	10W	180min
BC5401J-L2×20		20W	90min

Fitting ordering information (Optional)

Order No.	No.	Specification	Quantity
P03	1	Side wall bracket	2
	2	M10 Inner six angle bolt	4

Emergency box ordering information (Standard)

Order No.	No.	Specification	Quantity
BXP01	3	Explosion-proof emergency box	1
	4	Bracket	1

Lamps ordering information

Order No.	Installation	Emergency wattage	Emergency duration
BC5401J-L2×10	Rod	10W	180min
BC5401J-L2×20		20W	90min

Fitting ordering information (Optional)

Order No.	No.	Specifications Model	Quantity
P04	1	Upper hoop	2
	2	Under hoop	2
	3	Dn32 Poles	1
	4	U tube clip	2
BXP01	5	Explosion-Proof Emergency Box	1
	6	Bracket	1

Lamps ordering information

Order No.	Installation	Emergency wattage	Emergency duration
BC5401J-L2×10	Pole	10W	180min
BC5401J-L2×20		20W	90min

Fitting Ordering Information (Optional)

Order No.	No.	Specification	Quantity
P05	1	Pole mounting bracket	1
	2	19cm Screw(M8)	1
P02	3	Connector G3/4" male- male	1
BXP01	4	Explosion-proof emergency box	1