

BC9300 Explosion Proof Platform Light

TORMAN

Ex

IP
65

Ta
40

Ta
-20



Ex marking: Ex d IIC T4 Gb

Application

- Ideal to be used in the environment of flammable gas and steam environment, such as Drilling platform, Petrochemical Plant, Chemical Plant, Pharmaceutical Factory, etc.
- Zone1,zone2.



Characteristics

- Equipped with international famous brand light source and electrical appliance, more stable performance and gives approximately 20% more light over the other manufacturer's.
- It uses dual-cavity explosion-proof design, making it safe to be used in explosive and flammable places.
- Made of aluminium alloy, high strength. The spray coating treatment ensure the lamp waterproof, anti corrosion.
- The protective guard is available.

Main Specification

Item	Technical Parameters
Input voltage (V)	220VAC
Rated frequency	50Hz
Light source	MH Mercury
Life time (h)	10,000
Leading-in cable diameter	φ 9mm~ φ 14mm
Cable entry	G3/4"
Dimension (mm)	Lamp φ 200×315
	Ballast 230×220×105
Net weight (kg)	Lamp 5.2
	Ballast 3.8

Light distribution curve

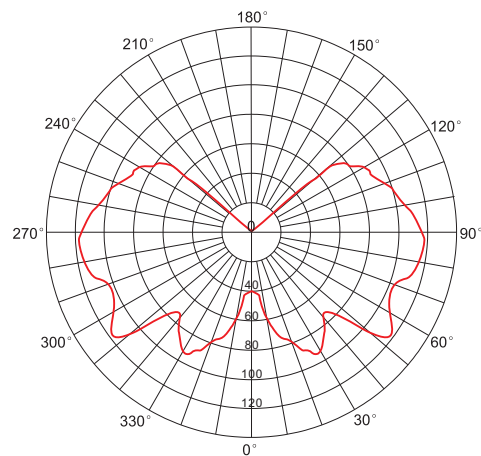

Ordering Reference

Model number	Rated Wattage (W)	Light output (lm)	Space height ratio	Mounting height (m)
BC9300-J70	70W	4725	1.75	2~6m
BC9300-J100	100W	6750		
BC9300-J150	150W	10500		

Drawing of dimension (Dimensions in mm)

Ceiling Mounting (optional)

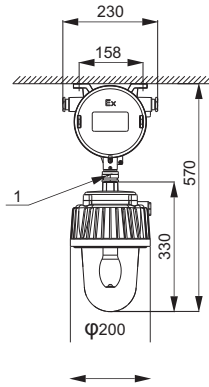

Side wall mounting 90°

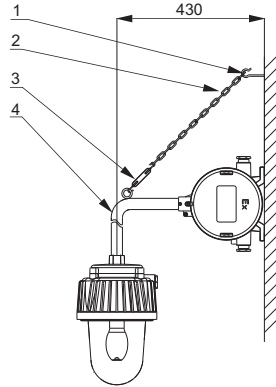

Side wall mounting 150°

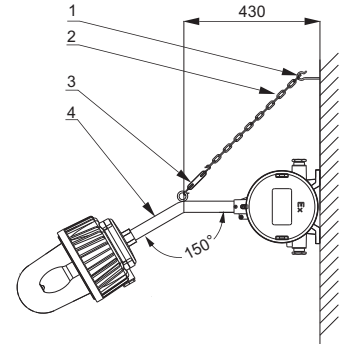

Accessories order information(Ceiling Mounting)

Order number	No.	Specification	quantity
P09	1	G3/4" internal to external	1

Accessories order information(Wall mounting 90deg)

Order number	No.	Specification	quantity
P04	1	Expansion screw hook	1
	2	Chain	1
	3	C-C turn buckle	1
	4	G3/4" bend pipe 90°	1

Accessories order information(Wall mounting 150deg)

Order number	No.	Specification	quantity
P03	1	Expansion screw hook	1
	2	Chain	1
	3	C-C turn buckle	1
	4	G3/4" bend pipe 150°	1

Guardrail mounting

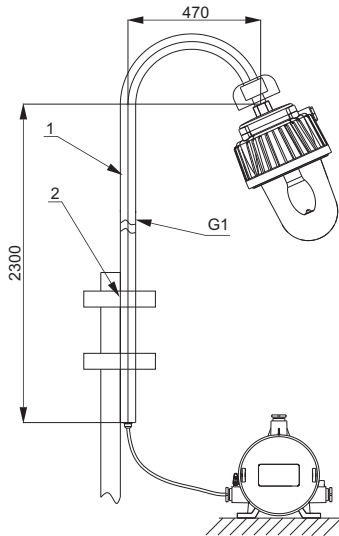

Flange mounting

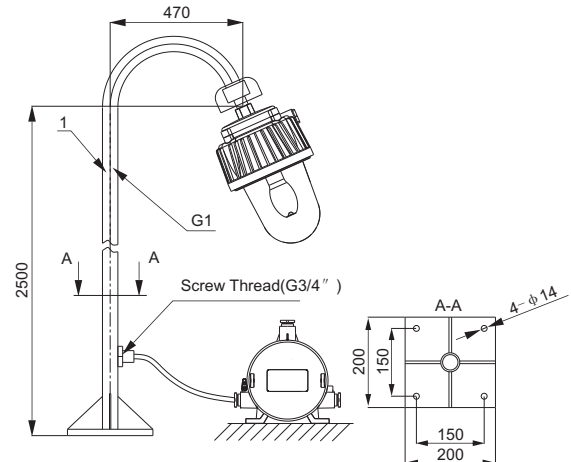

Accessories order information(Guardrail mounting)

Order number	No.	Specification	quantity
P05	1	Guardrail pole	1
	2	U type bolts	2

Accessories order information(Flange mounting)

Order number	No.	Specification	quantity
P06	1	Flange pole	1